

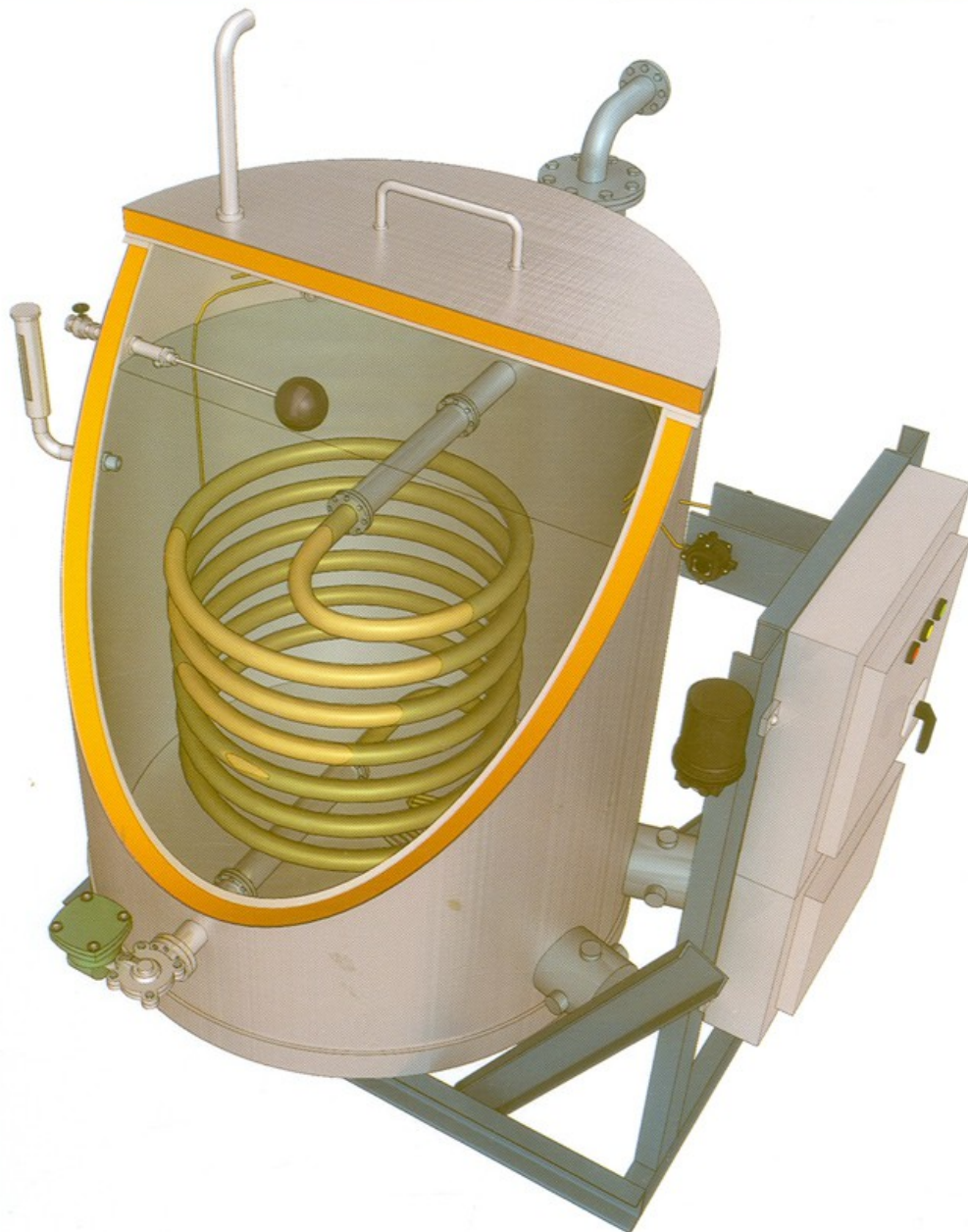

OIL & GAS PLANT ENGINEERS (I) PVT. LTD.

MANUFACTURERS OF  
**LPG VAPORIZERS**



## COMPANY PROFILE

Established in 1993 as a specialized unit for manufacturing critical equipment for hydrocarbon industry, OGPE is built on the principles of safety, quality, reliability, ease of operation, energy conservation and 'installation & maintenance'.

With long and rich experience in the field, we have succeeded in designing novel vaporizer models for LPG/Propane/Ammonia service in electrical and steam heating designs besides our flagship hybrid design. We offer energy efficient, reliable and maintenance free vaporizers, which compete with global best designs.

We are also in the business of manufacturing complete pressure reduction stations and metering skids for natural gas service, LOT systems, sliding vane positive displacement pumps and air/water cooled non-lubricated compressor assemblies for transfer of liquid and gas products with main equipment sourced from our principals Blackmer, USA. These products are used in variety of industries including LPG, chemical processing, refined fuels, petroleum, food & sanitary and the mobile transport industries. We also offer gas leak detection systems for a very wide range of flammable and toxic gases, in association with New Cosmos Electric Co. Ltd, Japan in both portable as well as fixed type designs.

We have supplied these equipment to very prestigious companies in the private and public sector in India as well as in the overseas markets across Middle East and Africa. Our Clients vouch for the quality of our products, work ethics and our efficient post sales services.

## SALIENT FEATURES OF LPG VAPORIZERS

- Properly formed stainless steel coil on coiling machine.
- External liquid trap
- Flame and explosion proof solenoid valve on liquid inlet.
- Flame and explosion proof pressure switch on vapour outlet.
- Thermostats for automatic operation
- Safety valve on vapour outlet
- Pressure gauge
- On board flame & explosion proof control panel complete with cabling
- Insulated body for energy conservation.
- Water level indicator
- Packaged unit – ready to install
- Safe and reliable
- Low operational and maintenance cost

## OPTIONAL FEATURES

- RTD/Digital temperature controller
- High level switch on vapour outlet
- Automatic water level controller
- Hybrid operation with steam coil.

## APPROVALS

- Approval No.PV(M) — 528 dtd.08/12/2012 from Explosives Department, Nagpur

# LPG VAPORIZERS

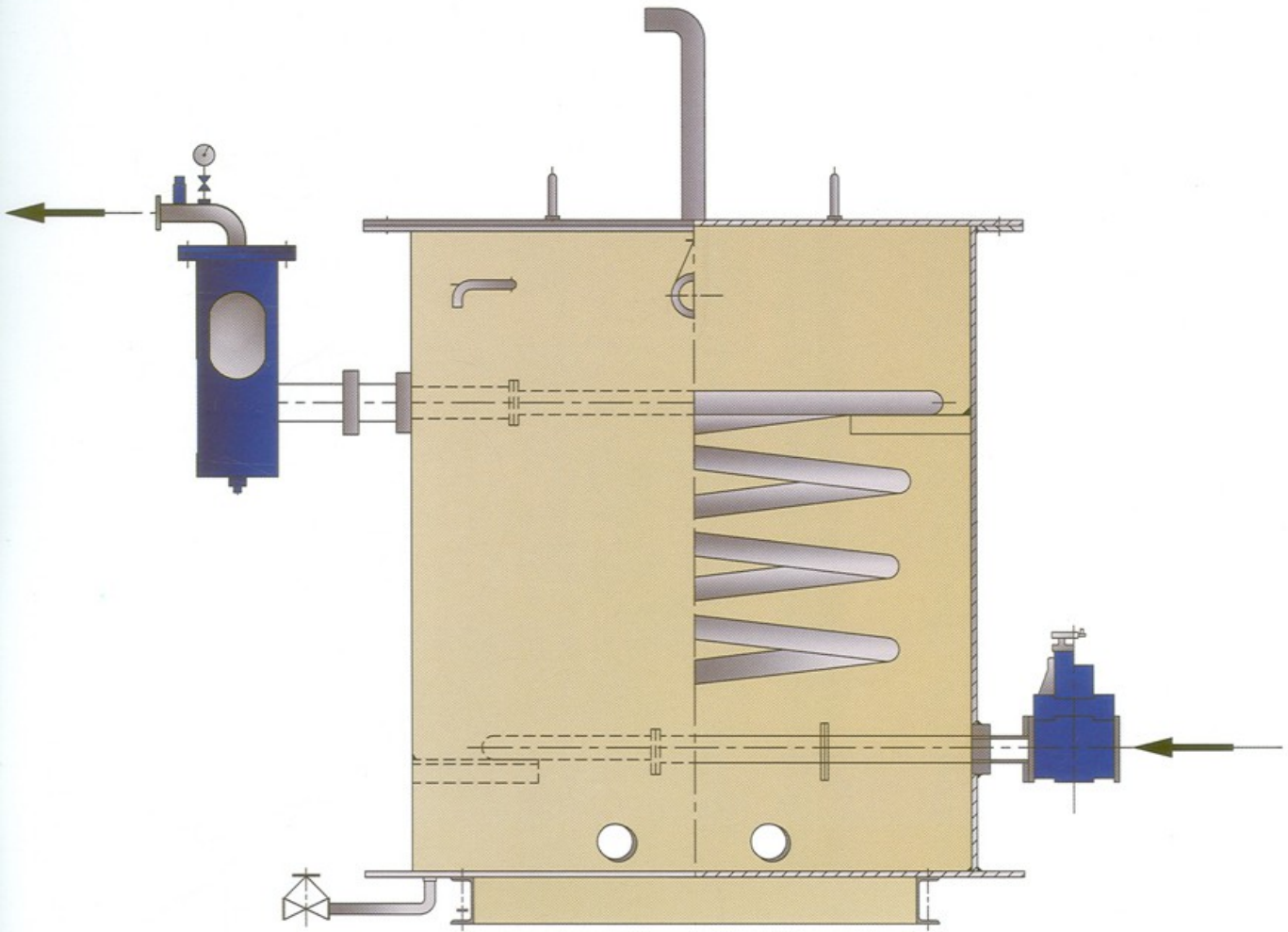

## ELECTRICAL/STEAM HEATED WATERBATH DESIGN

MODEL OGPE-P-E

CAPACITY : 25Kgs/HR TO 1000 kgs/hr

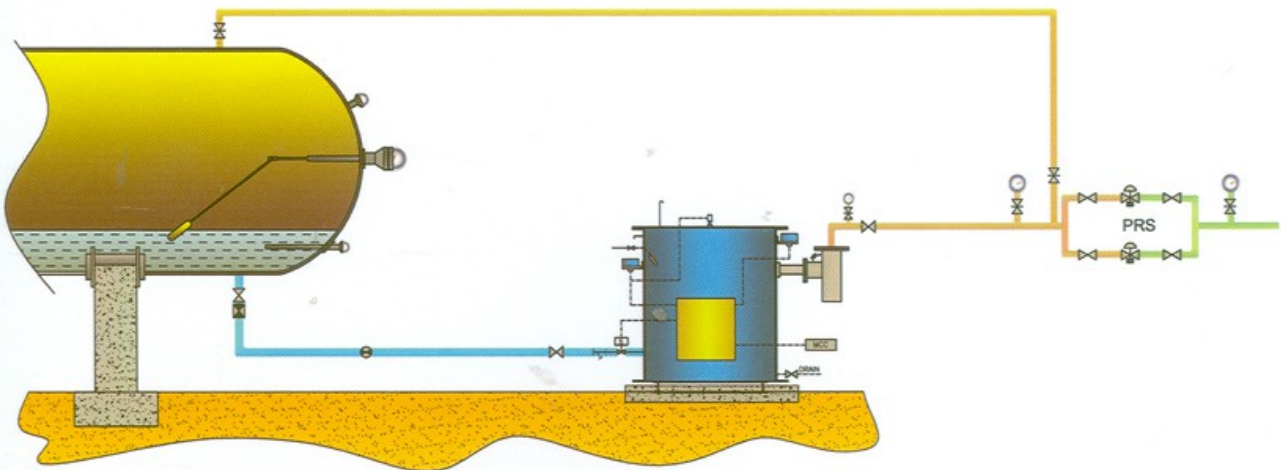

## TYPICAL VAPORIZER INSTALLATION

## OTHER PRODUCTS OF M/S. OGPE

COMPRESSOR  
PACKAGES

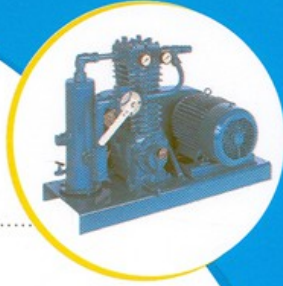

PUMP  
PACKAGES



PRESSURE REDUCTION &  
METERING STATIONS



GAS LEAK  
DETECTION SYSTEMS



LOT  
SYSTEMS

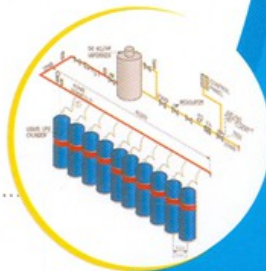

LPG LOADING  
ARMS

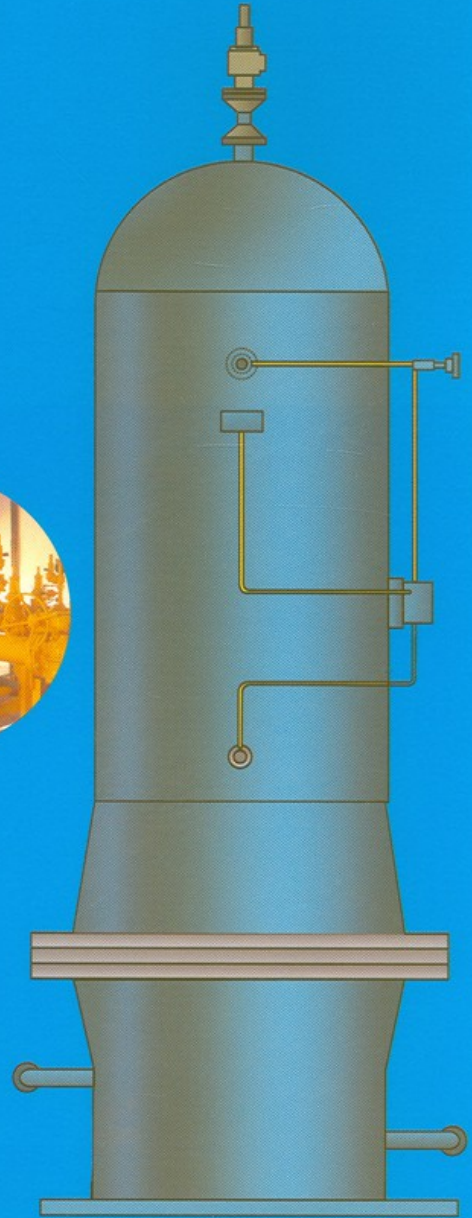

**SHELL AND TUBE TYPE VAPORIZER**  
STEAM/HOT WATER HEATED  
MODEL OGPE-S  
CAPACITY : 500 Kgs/HR TO 5000 kgs/hr



**HEAD OFFICE:**  
OIL & GAS PLANT ENGINEERS (I) PVT. LTD.  
Shed No.4, 14/3, Mathura Road  
Faridabad – 121003 (Haryana) India  
PH: 0129-4040818 / 4041816  
Fax :0129 4040818  
E-mail: ogpe@ogpeindia.com  
Website: www.ogpeindia.com

**WESTERN REGION:**  
1011 Akik Complex,  
Opposite Rajpath Club,  
S.G. Highway, Bodakdev,  
Ahmedabad- 380054  
Phone: 09427335657  
Fax: (079) 40040485

**SOUTHERN REGION:**  
Contact: Mr. K.Vijay Kumar  
E-mail: vijay@ogpeindia.com  
Mobile: 08870266680